

## 変更履歴

## History of revisions

変更年月日 Date		変更事項 Description	承認 Approved by	作成 Prepared by
Ver.2	2005. 3.07	A change from the first version. 1.Packing Instruction for Pallet.	2005.3.14 AVG 技術1課 土屋	2005.3.14 RM 商品技術課 生井
Ver.3	2008. 6.10	Additionally Protection tape 7.3 Parts name marking (Bar-code label) Change CELL CODE 1-756-378-11 => 1-756-378-12	2007.7.15 L・Pパック 設計部 佐々木	2007.7.11 LI技術3課 堀江
Ver.4	2009. 3.27	Additional. SONY parts name US-T180GDVT1 AE SONY parts number F-4991-157-0 7.3 Parts name marking US-T180GDVT1(AE)	2009.3.31 L・Pパック 設計部 土屋	2009.3.30 LI技術3課 加藤
Ver.5	2009. 8.26	Air transport specifications addition SONY parts name US-T180GDVT1 E SONY parts code F-4991-157-1 7.Packing 7.1 Packing instruction 7.1.1 Boat transport specifications 7.1.2 Air transport specifications 7.2 Printing Instruction for Master carton 7.2.1 Boat transport specifications 7.2.2 Air transport specifications 7.3 Parts name marking 7.3.1 Boat transport specifications 7.3.2 Air transport specifications 7.4 Packing instruction for Pallet 7.4.1 Boat transport specifications 7.4.2 Air transport specifications	2009.9.2 SEND LP Pack Sanpei	2009.9.1 SEND LI3 Kato
Ver.6	2009. 10.8	Additional. SONY parts name US-T180BMVT1 E US-T180BMVT1 WG US-T180BMVT1 G SONY parts number F-4973-541-0 F-4973-542-0 F-4973-543-0 7.3 Parts name marking US-T180BMVT1(E) US-T180BMVT1(WG) US-T180BMVT1(G) Indication change 7.4 Packing Instruction for Pallet	2009.10.18 SEND LP Pack Sanpei	2009.10.13 SEND LI3 Kato
Ver.7	2010. 10.14	Cell top cover material change ・4.5.2 Impedance specification More than 20mΩ Less than 30mΩ => More than 19mΩ Less than 29mΩ ・7.3 Parts name marking, 9.3 Parts name marking CELL CODE 1-756-378-12 => 1-756-378-13		

## Contents

1. General .....	4
1.1 Scope .....	4
1.2 Product Category .....	4
1.3 Model Name .....	4
1.4 Applicable Safety Standard.....	4
2. Cell Rating	
2.1 Nominal Capacity.....	4
2.2 Minimum Capacity .....	4
2.3 Nominal Voltage.....	4
2.4 Charge Voltage .....	4
2.5 Cut Off Voltage.....	4
2.6 Maximum Charge Voltage.....	4
2.7 Continuous Maximum Charge Current.....	4
2.8 Continuous Maximum Discharge Current .....	4
2.9 Weight.....	4
2.10 Allowable Cell Surface Temperature.....	4
3. Shape / Dimension and Appearance .....	4
3.1 Shape/Dimension .....	4
3.2 Appearance .....	4
4. Performance .....	5
4.1 Standard Test Condition .....	5
4.2 Testing Instrument or Apparatus.....	5
4.3 Standard Charge definition .....	5
4.4 Standard Discharge definition.....	5
4.5 Electrical Performance.....	5
4.6 Mechanical Performance.....	6
5. Warning and Recommendation for Using the Lithium Ion Rechargeable Battery.....	6
5.1 Prohibition Clause.....	6
5.2 Charging .....	6
5.3 Discharging .....	6
5.4 Storage.....	6
5.5 Safety Design .....	7
5.6 Recommended Block diagram for Safety Design .....	7
5.7 Pack Assembly .....	7
5.8 Identification and Marking.....	7
6. Outline.....	8
7. Packing.....	9
7.1 Packing Instruction .....	9~10
7.2 Printing Instruction for Master Carton.....	11~12
7.3 Parts name marking.....	13~14
7.4 Packing Instruction for Pallet.....	15

## Lithium-Ion Battery Specifications

## 1. General

## 1.1 Scope

This specification is applied to Lithium-Ion Battery provided by Sony.

- 1.2 Product Category: Lithium-Ion Battery  
 1.3 Model Name US18650VT  
 1.4 Applicable Safety Standard UL1642: File No.MH12566

## 2. Cell Rating

Item	Rating	Note
2.1 Nominal Capacity	1080mAh	1.0C Discharge, 2.5V cut off Standard Charge
2.2 Minimum Capacity	1000mAh	1.0C Discharge, 2.5V cut off Standard Charge
2.3 Nominal Voltage	3.6V	
2.4 Charge Voltage	4.10±0.05V	
2.5 Cut Off Voltage	2.5V	
2.6 Maximum Charge Voltage	4.15V	
2.7 Continuous Maximum Charge Current	8A	
2.8 Continuous Maximum Discharge Current	10A	
2.9 Weight	43.2 g or less	
2.10 Allowable Cell Surface Temperature	Charge	0~+45°C
	Discharge	-20~+60°C

※ Cell condition at the shipment About 70% discharged.

## 3. Shape/Dimension and Appearance

## 3.1 Shape/Dimension (ref. P8 6. Outline)

Max Diameter included tube on crimped portion.	18.2 +0.15 / -0.2mm
Diameter included tube.	18.1 ±0.2 mm (excluding wrinkle on the tube)
Overall height.	64.90 ± 0.2mm

## 3.2 Appearance (specified by limit samples)

It shall be free from any defects such as remarkable scratches, leakage or deformation.

#### 4. Performance

##### 4.1 Standard Test Condition

Test condition shall be at  $23 \pm 2^\circ\text{C}$  and  $65 \pm 20\%$  R.H. However, it can be at  $15 \sim 30^\circ\text{C}$  and  $25 \sim 85\%$  R.H. as long as there is no doubt. The humidity can be any condition unless it affects the test results.

##### 4.2 Testing Instrument or Apparatus

###### 4.2.1 Dimension Measuring Instrument

The dimension measurement shall be implemented by instruments with equal or more precision scale of 0.01mm specified by JIS B 7502(outside micrometer) or JIS B 7503(dial gauge).

###### 4.2.2 Voltmeter and Ammeter

Voltmeters and ammeters shall be equal or more precision instruments specified by JIS C 1102 (Indication Electric Instrument Level 0.5).

###### 4.2.3 Impedance Meter

Impedance shall be measured by a sinusoidal alternating current method (1kHz LCR meter).

##### 4.3 Standard Charge definition

Standard charge is defined by charging for current of Maximum 1A to 0.1A at 4.1 ( $\pm 0.005$ ) V of constant Voltage.

##### 4.4 Standard Discharge definition

Standard Discharge is defined by discharging at for current of Maximum 1.0A down to 2.5V at  $23 \pm 2^\circ\text{C}$ .

##### 4.5 Electrical Performance

Item	Condition	Specification
4.5.1 Open-Circuit Voltage	Shipping condition	More than 3.40V Less than 3.80V And the same lot is within 0.1V.
4.5.2 Impedance	After standard charge within 3 days.(1kHz)	More than 19m $\Omega$ Less than 29m $\Omega$
4.5.3.1 Capacity	The capacity on standard discharge, after standard charge	1000mAh or more
4.5.3.2 Capacity(2)	The capacity on 1.0CA(1.0A) discharge at 2.5V cut off, after standard charge	1000mAh or more
4.5.3.3 Capacity(3)	The capacity on 4.0CA(4.0A)/100mA cut off, after standard charge, discharge at 4.0CA(4.0A)/2.5V cut off	960mAh or more
4.5.3.4 Capacity(4)	The capacity on 4.0CA(4.0A)/100mA cut off After standard charge discharge at 10.0CA(10.0A)/2.5V cut off	910mAh or more
4.5.4 Charge/Discharge Cycle	The capacity on after standard charge $\Leftrightarrow$ 10.0CA(10.0A) discharge at 2.5V , after 250cycles	768mAh or more

8

4.5.5 Discharge capacity by Temperature.  Discharge : 4.0CA(4.0A)/2.5V Cutoff Charge : 4.0CA(4.0A)/0.1A Cutoff	The capacity discharged under the ambient temperature listed below after standard charge	More than the Value in the left Table.										
	<table border="1"> <tr> <th>Discharge Temperature</th> <th>Capacity</th> </tr> <tr> <td>-20°C</td> <td>672mAh</td> </tr> <tr> <td>0°C</td> <td>820mAh</td> </tr> <tr> <td>23°C</td> <td>960mAh</td> </tr> <tr> <td>45°C</td> <td>960mAh</td> </tr> </table>		Discharge Temperature	Capacity	-20°C	672mAh	0°C	820mAh	23°C	960mAh	45°C	960mAh
	Discharge Temperature		Capacity									
	-20°C		672mAh									
	0°C		820mAh									
23°C	960mAh											
45°C	960mAh											
4.5.6 Heat shock		No Leakage										
The battery pack shall be standard charged.												
Then it shall be stored during 10 cycles of the following temperature cycle.  60°C, 2h ↔ -20°C, 2h												

## 4.6 Mechanical Performance

Item	Condition	Specification
4.6.1 Vibration	<p>The battery pack shall be standard charged and tested under the following condition</p> <p>Frequency and acceleration :10~60Hz, 2.1G            Frequency and acceleration :60~80Hz, 1.4G            Frequency and acceleration :80~100Hz, 0.7G            Frequency and acceleration :100~125Hz, 0.4G</p> <p>5min. sweep, 1 hour for each axes</p> <p>After the first standard discharge and standard charge, the capacity of the second discharge must be more than data in the right specification column.</p>	<p>No leakage.</p> <p>860mAh</p>

## 5. Warning and Recommendation for Using the Lithium Ion Rechargeable Battery

## 5.1 Prohibition Clause

- Do not solder lead directly to the cell body.
- Do not short (+) and (-) terminal of the cell with a kind of metal.
- Do not throw the cell into fire, nor heat the cell.
- Do not add strong shock, nor drop the cell.
- Do not stub the cell with a nail etc., nor make a hole in the cell.
- Do not put into a microwave oven, nor high temperature container.
- Do not leave the cell in a place of high temperature.
- Do not connect cell to wall sockets and cigarette wall sockets etc. in vehicle.

## 5.2 Charging

- Charge within the limits of 0°C ~ +45°C cell surface temperature.
- Do not charge reversal.
- Charge only with charger exclusively designed for this battery.

### 5.3 Discharging

- Discharge within the limits of  $-20^{\circ}\text{C} \sim +60^{\circ}\text{C}$  cell surface temperature.
- Avoid discharging below 2.5V.
- Discharge within a designated current.
- Use only as a power source for a designated device.

### 5.4 Storage

- Store in less than  $20^{\circ}\text{C}$  ambient temperature area, and condition in container is also included.
- Use within 3 months ( 90 days ) after shipping .

### 5.5 Safety Design (ref. Fig.1 Block diagram of batteries for PCs)

The battery must shall three functions of Safety Design as follows.

- Over-charging protective design.  
Open circuit voltage of cell shall be less than 4.15volts per each cell at any condition.
- Over-discharging protective design.  
The over-discharging protective circuit shall operate at 2.0 to 2.5 volts, then the discharge current shall decrease to less than 10 micro amperes.
- Excessive-current protective design.  
The protective circuit shall operate at charging or discharging at over 10 C continuous current.  
The protective design to rush current and short terminal of battery current shall be required.

### 5.6. Recommended Block diagram for Safety Design

Depending on the battery pack configuration and charge/discharge conditions, certain safety components may be omitted.

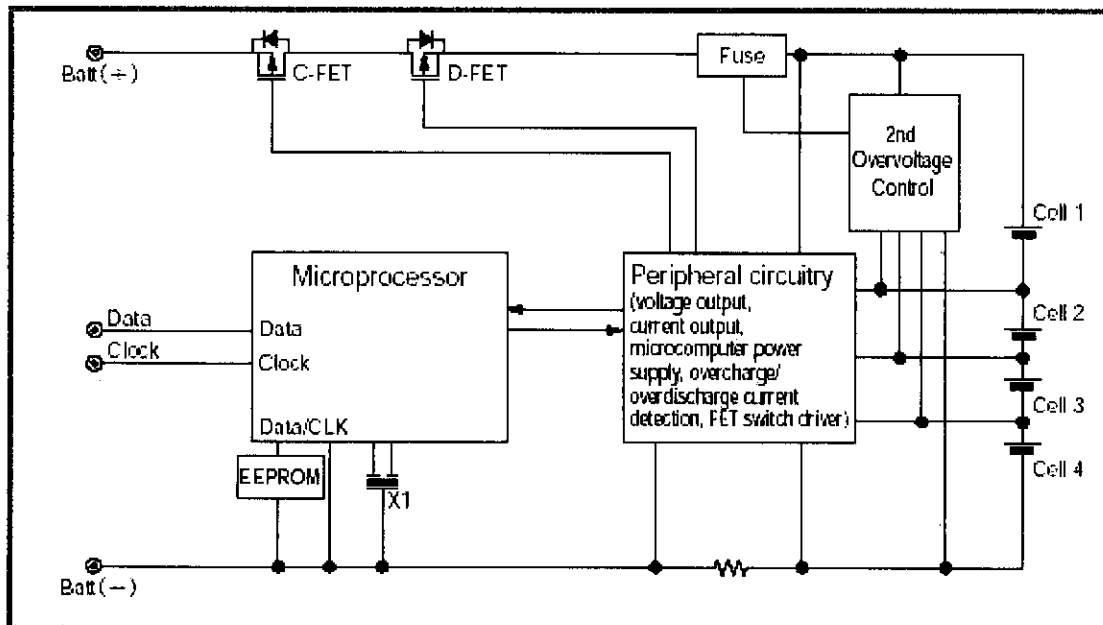

Fig.1 Block diagram of batteries for PCs.

### 5.7 Pack Assembly

- Use the same Lot Number(the Last 5 letters and figure) cells in a pack.

5.8. Identification and Marking (Lot Number Definition: Manufacturing Date of Cells)

The code is printed on a surface of the can, under the tube, at two lines.

5.8.1 Manufacturer (Trade name)

SE (Trade name of Sony Energy Devices Corp.)

5.8.2 Trade Mark (fig.2: USxxxxxxx)

US18650VT



Fig.2

5.8.3 Manufacturer (plant) (fig.2: A)

K: Sony Energy Devices Corp. Koriyama Plant. T: Sony Energy Devices Corp. Tochigi Plant.

5.8.4 Specification (fig.2.: HH)

VT1(Print: T1)

5.8.5 Lot Number (Manufacturing Date of Cells : YMDDS)

Y: Year '92 as A, Every next year is counted as B, C,... (Using an Alphabet letter)

M: Month January as A, the consecutive month as B, C,... (Using an Alphabet letter)

D: Day 01, 02, ...29,30,31 (Using figures)

S: Electrode History A,B,C,.. (Using an Alphabet letter)

5.8.6 Recognition Mark

Cf. mark of the right side of Fig.2

6. Outline

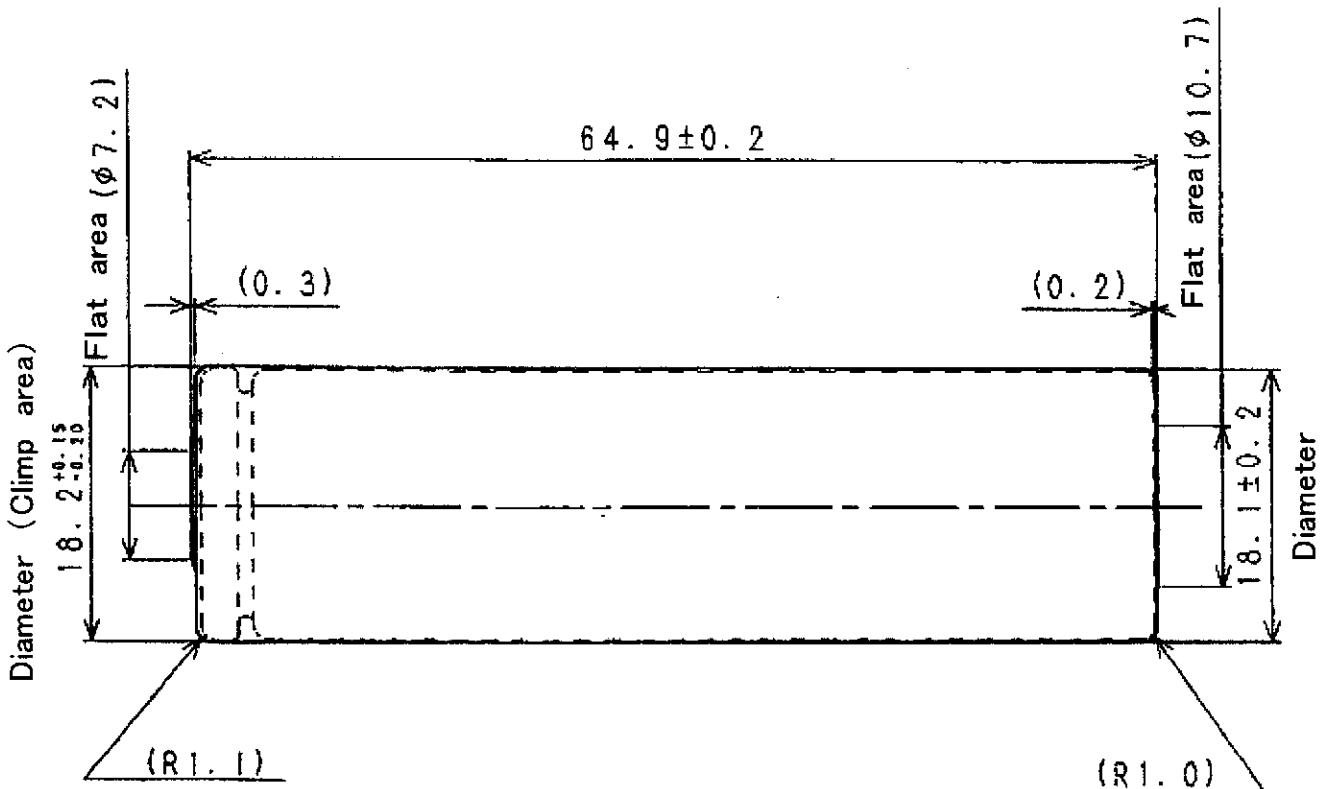

\* : Size excluding wrinkle on the Tube.

\* : Printing in above is an example.

7. Packing



7.1 Packing Instruction

7.1.1 Boat transport specifications

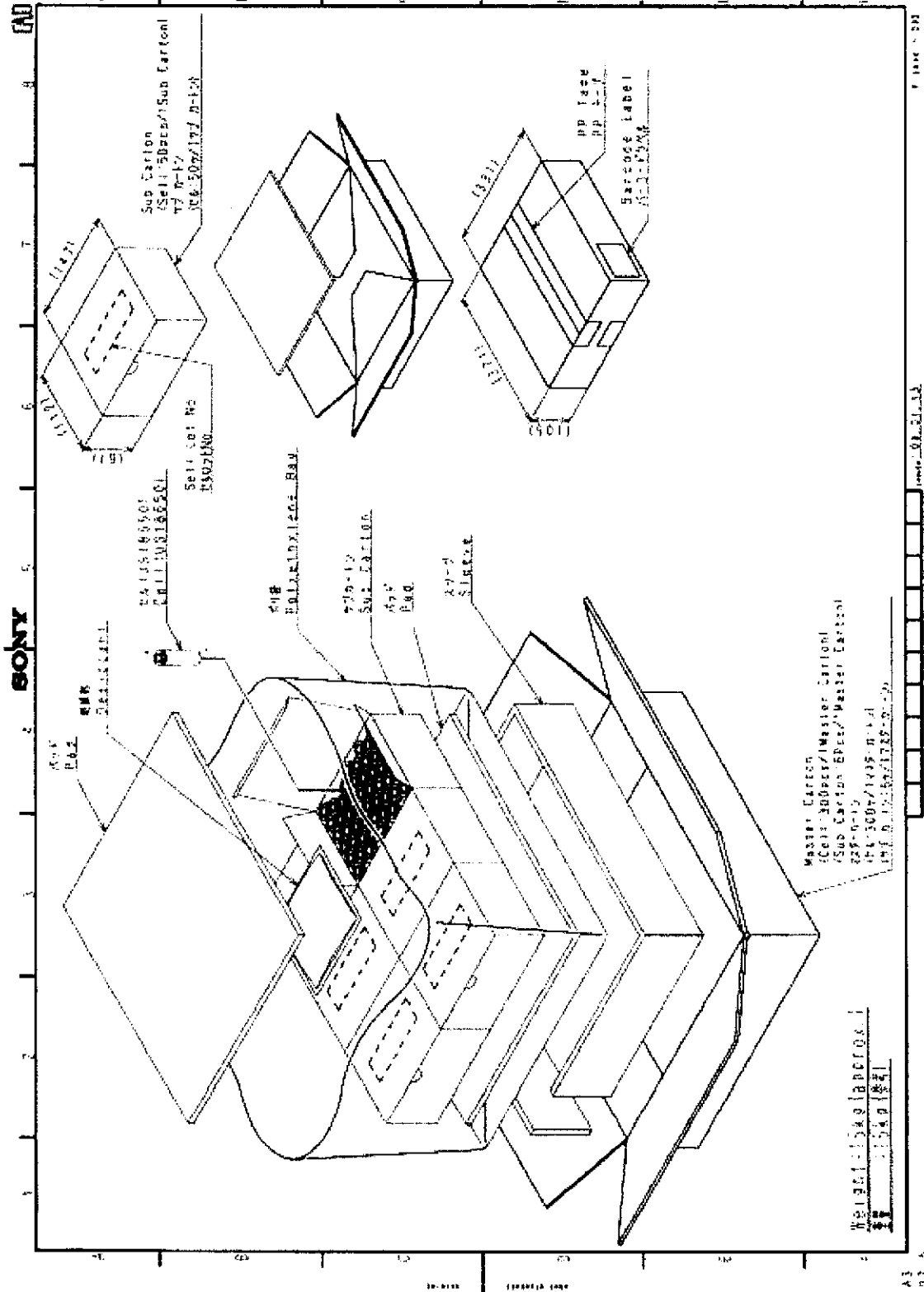



7.1.2 Air transport specifications

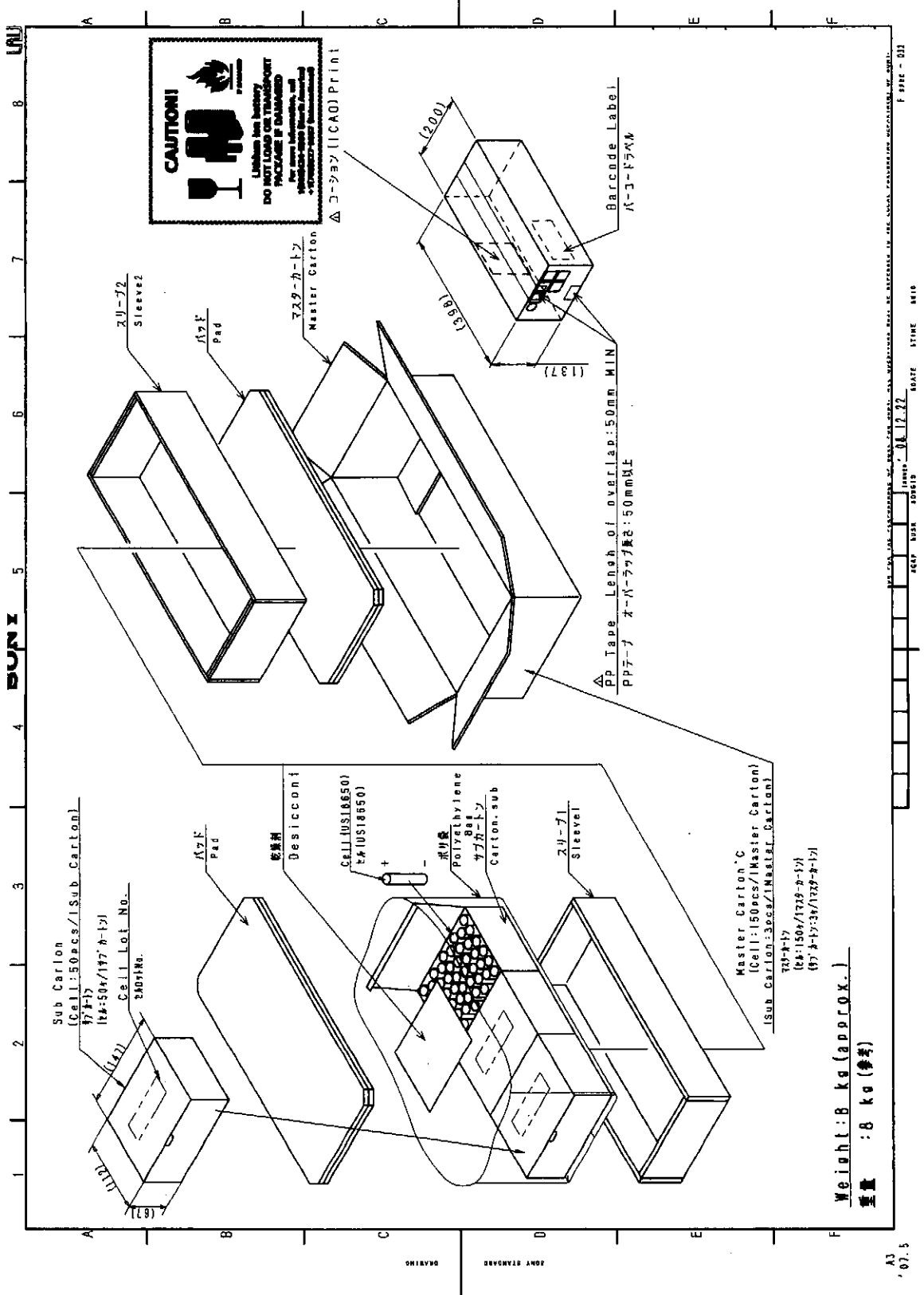

### 7.2 Printing Instruction for Master Carton

#### 7.2.1 Boat transport specifications

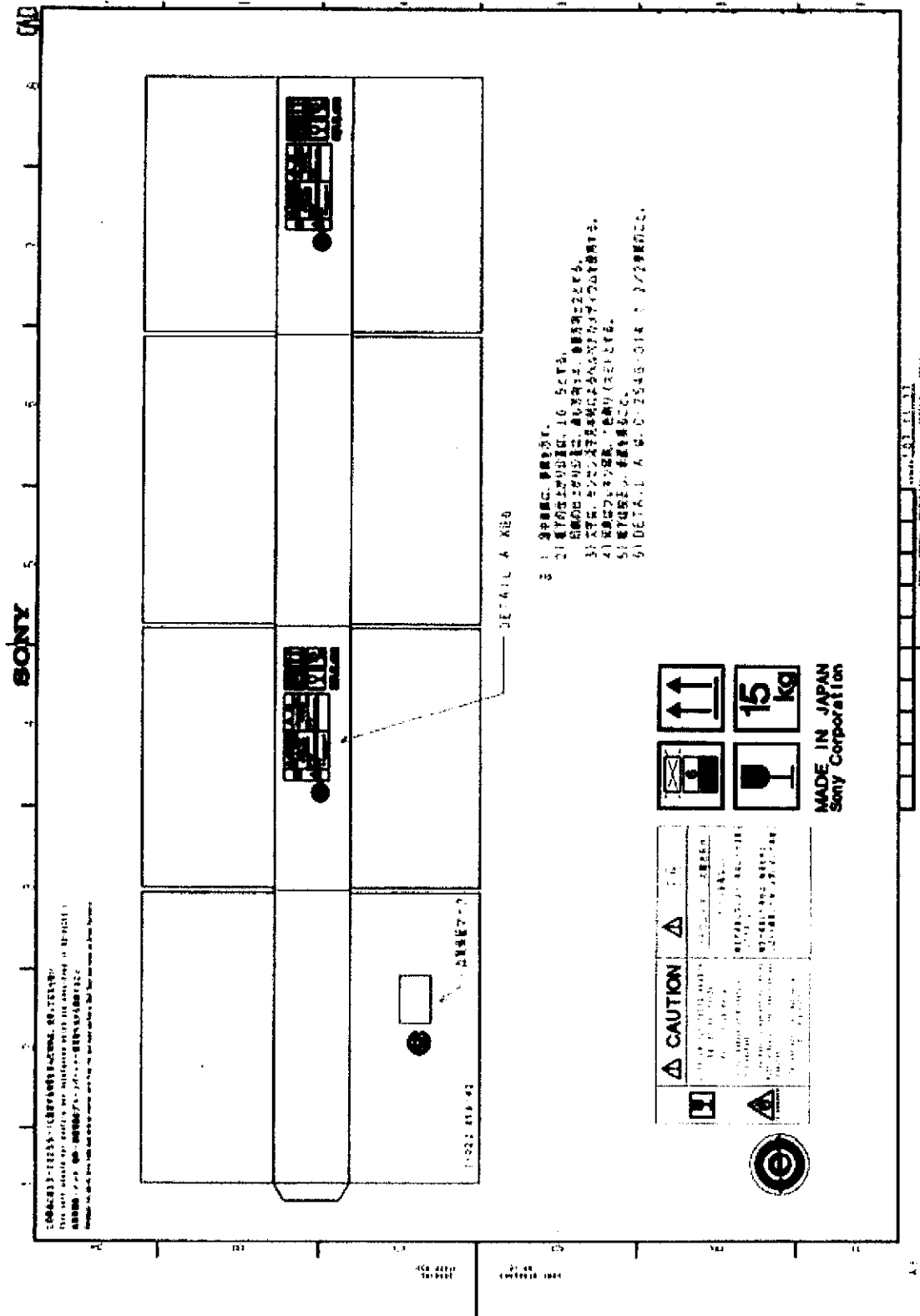

7.2.2 Air transport specifications

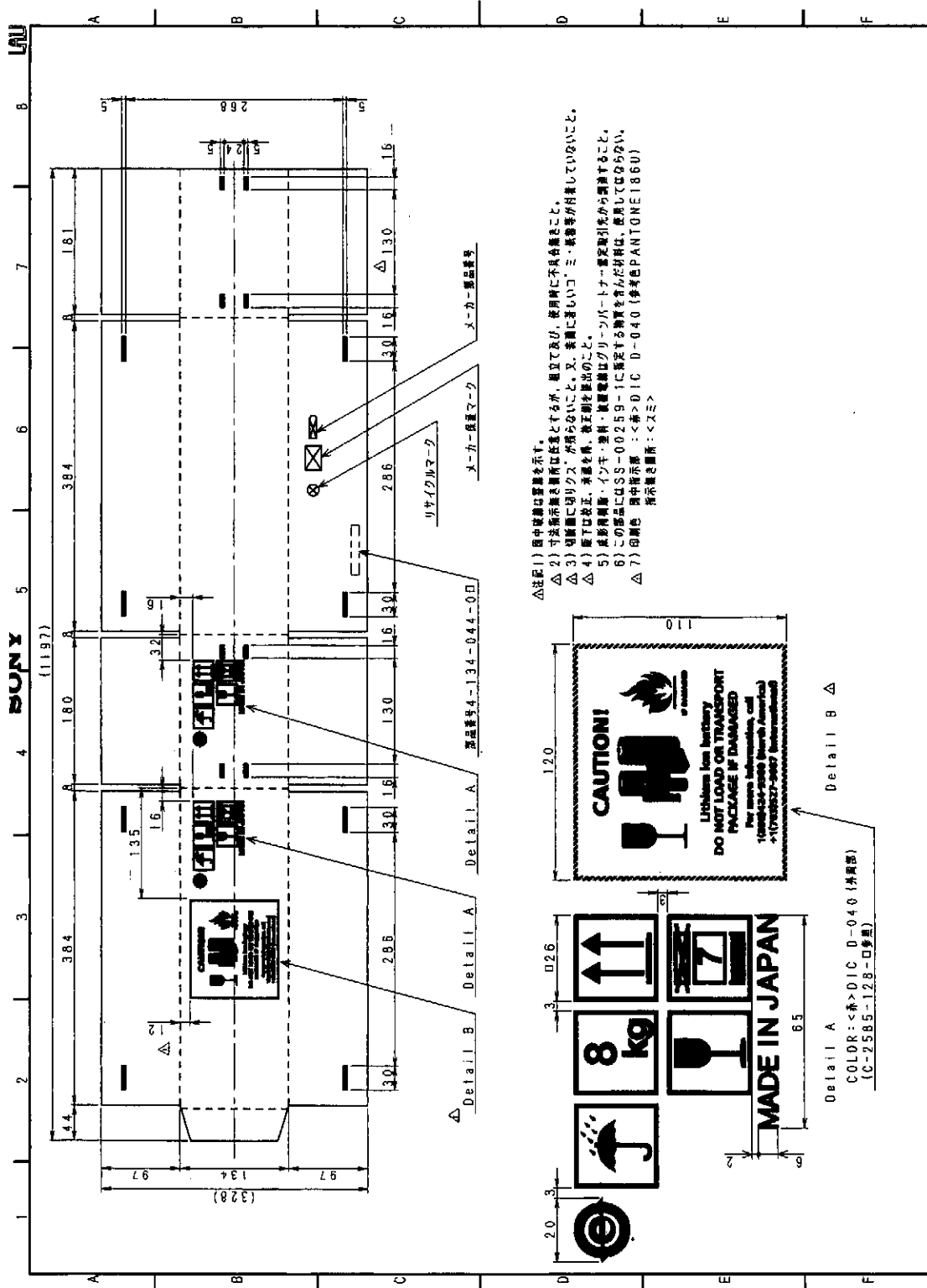

- △注記1) 国中製造品を示す。
- △2) 寸法表示は概略図に示す寸法とするが、組立て及び、使用時に寸法公差は、使用時に異なる場合がある。
- △3) 寸法表示は概略図に示す寸法とするが、組立て及び、使用時に寸法公差は、使用時に異なる場合がある。
- △4) 組立て及び、使用時に寸法公差は、使用時に異なる場合がある。
- △5) 組立て及び、使用時に寸法公差は、使用時に異なる場合がある。
- △6) この部品は、SS-00259-1に規定する荷役を要するが、取扱いに注意すること。
- △7) 印刷色 国中製造品：＜赤＞DIC D-040 (参考色PANTONE1860) 海外製造品：＜スミ＞

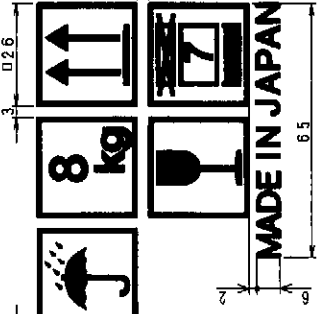
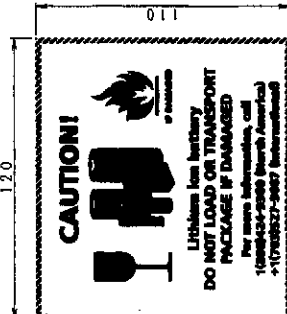

Detail A  
COLOR:＜赤＞DIC D-040 (赤黒)  
IC-2585-128-0 (赤黒)

Detail B △

7.3 Parts name marking. 4 8

A part name is marked on the bar code label of master carton. This bar code label is stuck to one places of master carton

5 7.3.1 Boat transport specifications  
US-T180BMVT1 AE , US-T180GDVT1 AE

MODEL NAME US-T180BMVT1 (AE)	MODEL CODE ***** CELL Lot No. ***** MASTER CARTON No. ***** MASTER CARTON Qty. ***** PACKING DATE ***** CUSTOMER CODE *****
MODEL CODE F49735400	
CELL NAME US18650VT (VT1)	
CELL CODE 1-756-378-13	
CELL Lot No. *****	
SUPPLIER Sony Energy Devices Corp.	

MODEL NAME US-T180GDVT1 (AE)	MODEL CODE ***** CELL Lot No. ***** MASTER CARTON No. ***** MASTER CARTON Qty. ***** PACKING DATE ***** CUSTOMER CODE *****
MODEL CODE F49911570	
CELL NAME US18650VT (VT1)	
CELL CODE 1-756-378-13	
CELL Lot No. *****	
SUPPLIER Sony Energy Devices Corp.	

7 US-T180BMVT1 WG

MODEL NAME US-T180BMVT1 (WG)	MODEL CODE ***** CELL Lot No. ***** MASTER CARTON No. ***** MASTER CARTON Qty. ***** PACKING DATE ***** CUSTOMER CODE *****
MODEL CODE F49735420	
CELL NAME US18650VT (VT1)	
CELL CODE 1-756-378-13	
CELL Lot No. *****	
SUPPLIER Sony Energy Devices Corp.	

7.3.2 Air transport specifications

6

US-T180GDVT1 E

MODEL NAME US-T180GDVT1(E)	MODEL CODE [Barcode]
MODEL CODE F49911571	***** CELL Lot No. [Barcode]
CELL NAME US18650VT (VT1)	***** MASTER CARTON No. [Barcode]
CELL CODE 1-756-378-13	***** MASTER CARTON Qty. [Barcode]
CELL Lot No. *****	***** PACKING DATE [Barcode]
SUPPLIER Sony Energy Devices Corp.	***** CUSTOMER CODE [Barcode] *****

7

US-T180BMVT1 G、US-T180BMVT1 E

MODEL NAME US-T180BMVT1(G)	MODEL CODE [Barcode]
MODEL CODE F49735430	***** CELL Lot No. [Barcode]
CELL NAME US18650VT (VT1)	***** MASTER CARTON No. [Barcode]
CELL CODE 1-756-378-13	***** MASTER CARTON Qty. [Barcode]
CELL Lot No. *****	***** PACKING DATE [Barcode]
SUPPLIER Sony Energy Devices Corp.	***** CUSTOMER CODE [Barcode] *****

MODEL NAME US-T180BMVT1(E)	MODEL CODE [Barcode]
MODEL CODE F49735410	***** CELL Lot No. [Barcode]
CELL NAME US18650VT (VT1)	***** MASTER CARTON No. [Barcode]
CELL CODE 1-756-378-13	***** MASTER CARTON Qty. [Barcode]
CELL Lot No. *****	***** PACKING DATE [Barcode]
SUPPLIER Sony Energy Devices Corp.	***** CUSTOMER CODE [Barcode] *****

7.4 Packing Instruction for Pallet 7

7.4.1 Boat transport specifications

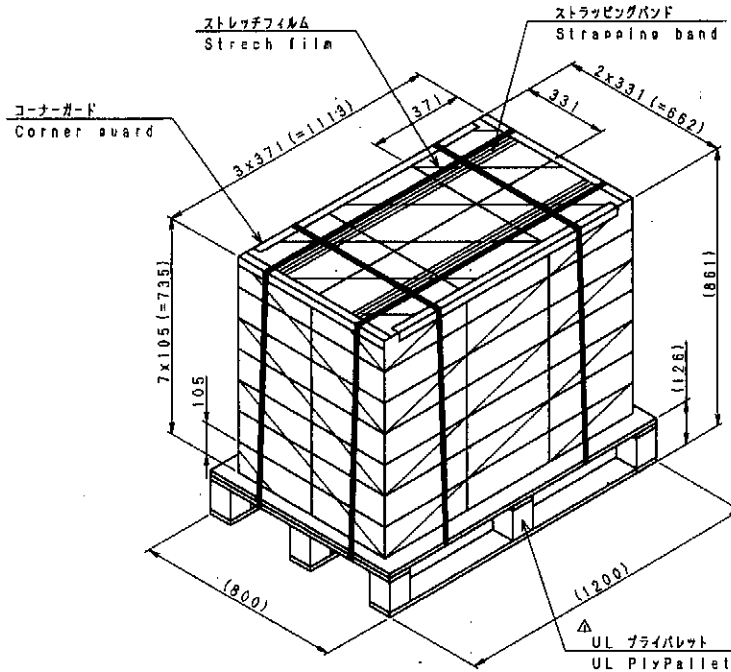

7.4.2 Air transport specifications

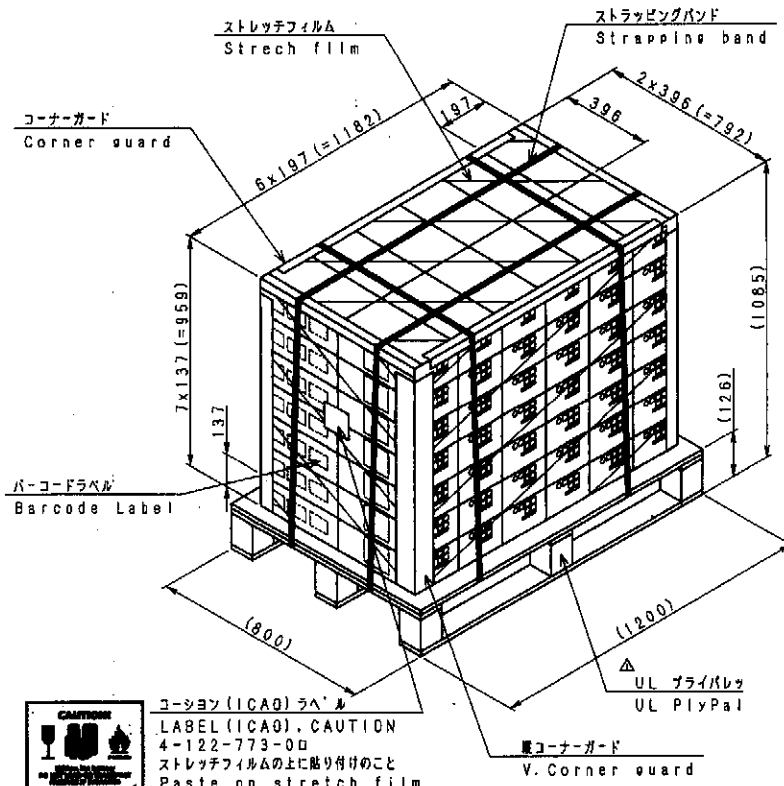

ユーティリティ (ICAO) ラベル  
UTILITY (ICAO) LABEL, CAUTION  
4-122-773-00  
ストレッチフィルムの上に貼り付けのこと  
Paste on stretch film